

# PRO SPOT

QUALITY WELDING SYSTEMS

## PR-5 Multi-Function Riveting System

**NEW!**

**Quick Connect Arm System**

### SMART

Will not perform a bad rivet. On-board system performs the same strength pressure (regardless of battery level) with full, half full, or almost empty battery. Battery voltage does not affect the force power.



### ALL IN ONE

for all your riveting needs

- SPR
- Flow Form
- Blind
- Removal
- Flattening
- Punching

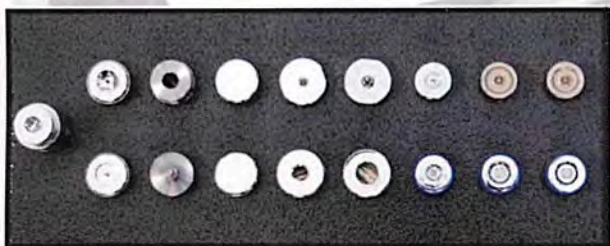

The PR-5 Multi-Function Riveting System combines multiple rivet applications in one versatile unit. The magnetic dies hold the rivets in place, making operation quick and easy. The arms and adapters quickly connect, to efficiently change operations. SMART features include a stop-and-go trigger for accuracy, force control and more.

**Totally portable**

Battery operated (lithium ion)  
Electric/Hydraulic System

# Riveter PR-5



## Applications:

- Self Piercing Rivets
- Solid Rivets
- Blind Rivets
- Flow Form Rivets
- Rivet Studs
- Rivet Nuts

## Technical Specifications

Performance Specs:	Force Range: 20-50kN Travel: 45mm Typ. Cycle Time: 3-5 sec
Power Source:	18V Battery (2ea) Charging Time: 2 Hrs Cycles/Charge: ~350 rivets
Standard Accessories:	Die Set for: SPR, SPR Removal, Flattening Calibrate Hole, Flow Form 55mm C-Arm
Optional Accessories:	Pull Adapter 120mm depth Arm 240mm depth Arm Custom Sized Arms

## Rivet Gun System

The Pro Spot PR-5 is designed to be the tool of today and tomorrow. The unique design allows for current attachments and adapters for various riveting applications. As the industry and repair demands change, the PR-5 design will allow future attachments to easily be added, making it the one-stop shop for rivet repair.

## Features:

- Easy to Use
- Used for Self-Piercing, Flattening and Rivet Removal
- Magnetic Punches for Quick Installation
- Smart Trigger System
- Portable, Battery Operated



## Multi-Function Riveting System

**55mm Arm**

**Extension Adapter**

**Lock Nut**

**Quick Change**  
Designed to quickly and easily change from one arm to another, saving time and hassle.

**SMART Trigger**  
Pause forward motion by releasing the trigger, very useful when fine adjustments of alignment are needed. Air/hydraulic systems don't have this feature.

**Release Button**

**Force Adjustment Knob**  
Set the final pushing force (range: 5kN [1,100lbs] to 50kN [11,000lbs]).

**Battery Operated**  
No hassle, no hoses and no cords. Uses 18V lithium-ion battery. On-board SMART system always provides correct hydraulic pressure regardless of battery voltage level.

**Easy Maneuvering Handle**  
Removable handle designed to easily balance and maneuver the Rivet Gun. The handle can be moved and used on either side.

The final force is NOT dependent on the charge level of the battery. Over 200 rivets per charge.

# Enhanced Rivet Gun Accessories

## Application Procedures

### Installing SPR's (Self Piercing Rivets)

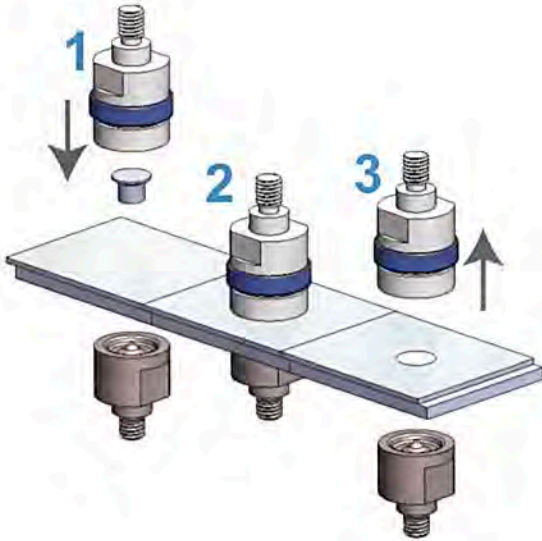

1. Align the removal dies in the center of SPR.
2. Complete pressure cycle so the male rivet die pushes the SPR through the base materials into the forming die.
3. Proceed to next rivet.



### New features include:

#### Enhanced Removal Die

The new removal die provides more robust removal of longer rivets (10mm), eliminating jamming and breaking where the previous SPR rivet was located. Using this system, SPR rivets can be removed in a fraction of the time it would take to drill out.

#### FLOW FORM RIVETS

In areas where you cannot fit an adjacent SPR or where repair procedures don't allow it, Flow Form Rivets are the answer. Becoming more popular in repair procedures, Flow Form uses a calibration punch, which allows a Flow Form Rivet to be installed in the same location as the original joint.

### Pro Spot's New Flow Form Rivet Process:

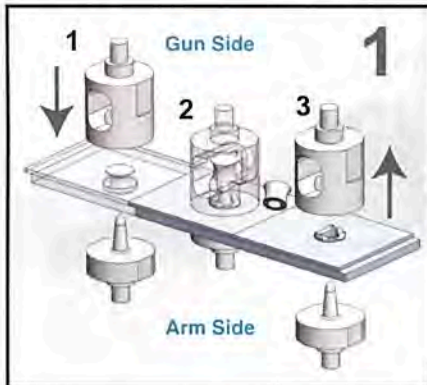

#### Removal

1. Align the removal dies in the center of SPR.
2. Complete pressure cycle so the male rivet die pushes the SPR into the receiving die.
3. The rivet is now extracted.

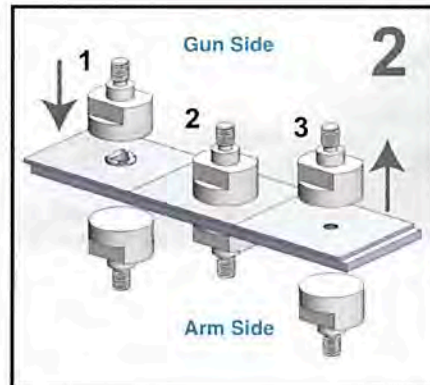

#### Flattening

1. Align the flattening dies in the center of hole.
2. Complete pressure cycle so the flattening dies compress the edges of the hole.
3. The area is now flattened.

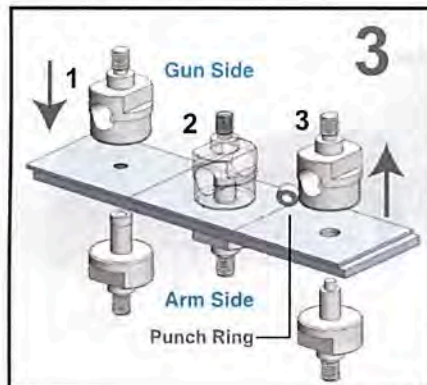

#### Punch Calibration

1. Align the calibration dies in the center of hole.
2. Complete pressure cycle to make exact hole size and collect the punch ring for reuse.
3. The hole is now ready for Flow Form rivet installation.

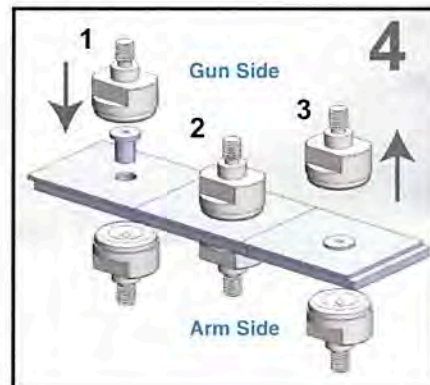

#### Installation of Flow Form rivets/ solid rivets

1. Align the dies in the center of rivet.
2. Complete pressure cycle so the Flow Form rivet is formed.
3. The installation of the Flow Form rivet is now completed.

Connect With Us:



# PR-5 Options

## Blind Rivet Adapter

The Blind Rivet Adapter seamlessly connects to the PR-5 Rivet Gun to allow users to quickly and easily install blind rivets.



- Patent Pending
- Adapts to Rivet Gun in 30 sec.
  - Pivots to any desired position
  - Enclosed Internal Hydraulic System

## Optimized Extended Reach Arms

Pro Spot's new Rivet Gun Arms have been redesigned to be more efficient, ergonomic and more accessible.

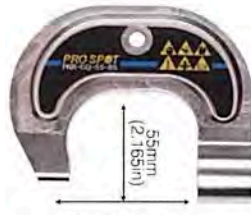

PRR-CQ-55-85



PRR-CQ-120-80

(optional)



PRR-CQ-240-120

(optional)

## Extender, Inserts, and Dies

### For Self-Piercing Rivets

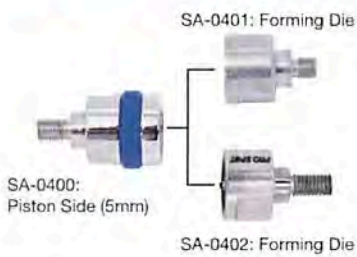

SA-0402: Forming Die



PRR-17: Self Piercing Die (3mm)

### For Removing Rivets



PRR-10HD: Rivet Removal Die, Male (5mm)  
PRR-11HD: Rivet Removal Die, Female (5mm)



PRR-12HD: Rivet Removal Die, Male (3mm)  
PRR-13: Female Rivet Removal Die (3mm)

### For Flow Form



PRR-FF11: Forming Side  
PRR-FF10: Rivet Head Side

### For Flattening



PRR-14: Flattening Die

### For Calibration Punch



PRR-C10, PRR-C11, PRR-C12: Calibration Dies



PR-5 Die Kit



PR-5 Complete System Comes With A Case